

■ Warranty

Immediate repair and/or part replacement shall be provided for breakage/poor condition to be clearly considered as our responsibility and to be generated within one year after our delivery from our factory. And only if the claimed defect arose during normal use, applications and service.

Consumable parts and their replacement shall be out of our warranty.

However, the following cases shall not be warranted.

- (1) In case of operating with % ED rate exceeding the limit and very high frequency.
- (2) In case of operating with the load more than the rated load.
- (3) In case of modifying the products and/or accessories without our approval.
- (4) In case of operating under very severe conditions exceeding the conditions of their specifications.
- (5) In case of operating, neglecting Caution/Danger items mentioned in this operation manual.

Any damage for production down to be caused by saddle damage shall not be warranted.

We will not supply any parts that become inoperative because of improper maintenance, eccentric loading, overloading, chemical or abrasive action, excessive heat, or other abuse.

Equipment and accessories not of our manufacture are warranted only to the extent that they are warranted by the manufacturer, and only if the claimed defect arose during normal use, applications and service.

EXCEPT AS STATED HEREIN, WE MAKE NO OTHER WARRANTIES, EXPRESS OR IMPLIED, INCLUDING WARRANTIES OF MERCHANTABILITY AND FITNESS FOR A PARTICULAR PURPOSE.

“Normal use, applications and service”: Those conditions during which a electric hoist, other products, equipment or accessories is (are) being operated and is (are) performing functions within the scope of the original design.

Caution

- Do not use our electric hoist or other products in an explosive atmosphere or corrosive environment.
- Do not use our electric hoist or products for passenger elevator application.

Our products are exempted from the scope of guarantee if exported to other nations regulated by the PL law than Japan.



Advanced technology and dedicated service
KAMIUCHI ELECTRIC WORKS, LTD.

HEAD OFFICE
5-31, TAGAWA 2-CHOME, YODOGAWA-KU,
OSAKA 532-0027, JAPAN
TEL:06-6301-6751 FAX:06-6308-0389

TOKYO OFFICE
22-7 3F, HAMAMATSU-CHO 1-CHOME, MINATO-KU,
TOKYO 105-0013, JAPAN
TEL:03-6402-4525 FAX:03-6402-4526

AYABE FACTORY
ENSHO, 1, TAKATSU-CHO, AYABE-CITY, KYOTO 623-0045,
JAPAN TEL:0773-42-1270 FAX:0773-42-6551

URL <http://www.kamiuchi.co.jp/>
E-mail oshi@kamiuchi.co.jp (OSAKA OFFICE)
toshi@kamiuchi.co.jp (TOKYO OFFICE)

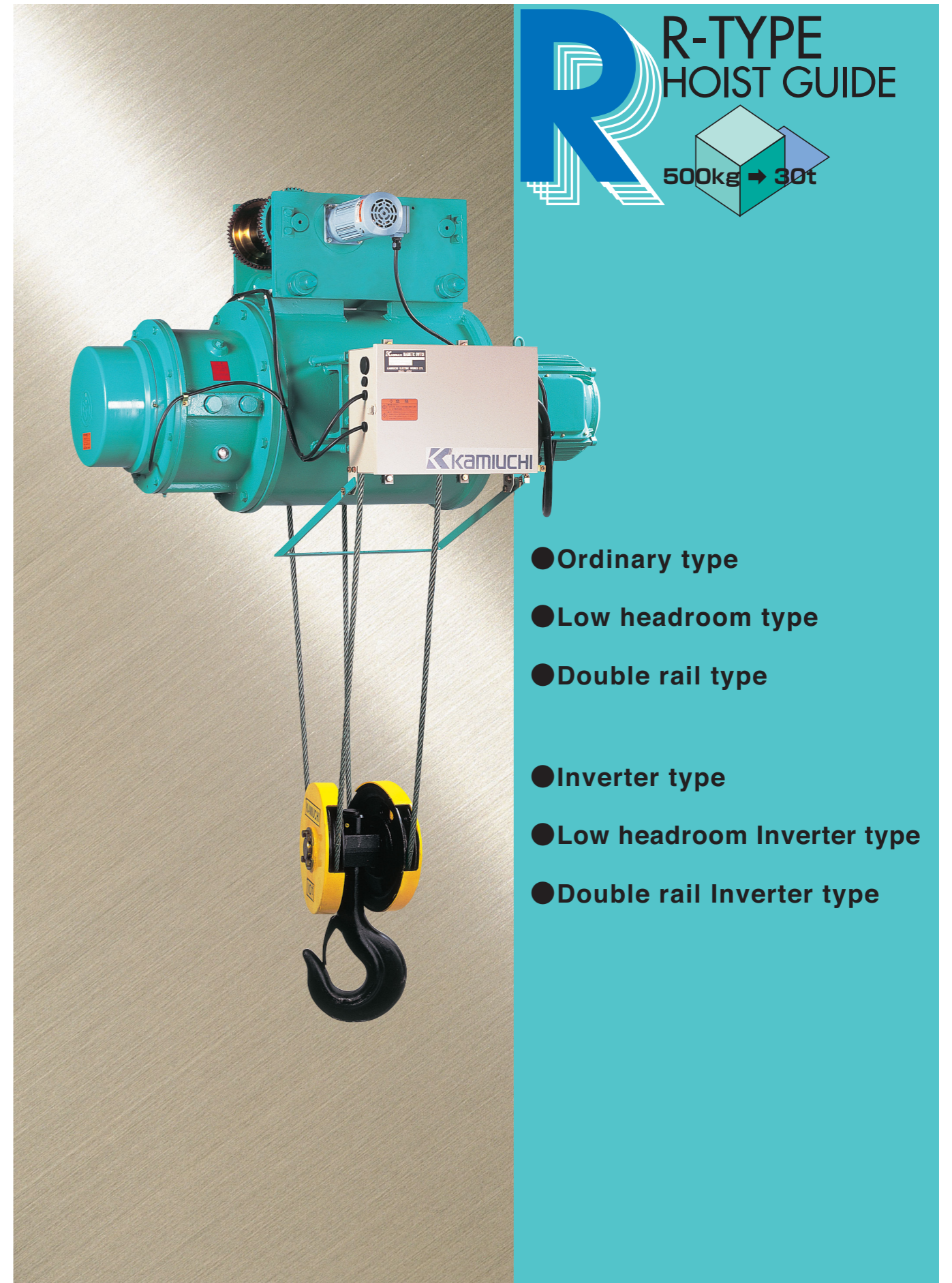

KAMIUCHI ELECTRIC WORKS, LTD.

APPLICATION OF CONSTRUCTION STANDARDS

Before selecting hoists, investigate operating and environmental conditions.

CHECK

1. [Capacity] How many tons is the lifting load ?
2. [Lifting] How many meters is the lifting height ?
3. [Operating conditions] ... Indoor or Outdoor ?
4. [Application] Up and Down, Up/Down and Left/Right, or Up/Down Plus East/West/South/North (Crane operation) ?
5. [Power supply] How many voltage and 50Hz or 60Hz ?

..... Rated load shows the maximum load which hoist can lift up.

Over load can not be admitted by the relative laws and regulation.
The most suitable normal load is 50-63% of the rated load for safety and long time operation.

..... Lifting height is the height to lift up the load.

Select the height at the time when the hook reached the ground.
It is regulated that more than two rounds of wire should remain on the drum at the lowest position.

SPECIAL OPERATING CONDITIONS

There would be case where the standard hoist can not be used according to operation and/or environmental conditions. KAMIUCHI have been manufacturing lots of special hoists in order to comply with wide requests from our customers. Pay attention to the following conditions.

1. Different voltage

Instruct voltage and frequency other than standard power supply 3 phase AC200V 50/60Hz and AC220V 60 Hz.

2. Designation of control voltage

In case of different voltage and less than 200V, a transformer is to be required and so instruct it to us.

3. Operating environment

Indoor operation is a standard. In case of outdoor operation, the housing is necessary. Standard specification can be applied to small amount of dust. Special specifications are to be required for applications where acid and/or steam exist. No anti-explosive type is available.

4. Alteration of speed

In case both low or high speed is to be required, there is a case that the modification can be made with the same model or a case that the alteration of the model is necessary.

5. Stationary type

Stationary type, which can be used as winch, is manufactured separately.

6. Lifting height

In special high lifting height type of ordinary type hoist the lifting height up to 45m is standardized.
(In case of double rail type, up to 36m)

CLASSIFICATION OF LIFTING DEVICE

Load rate	Total operating hour (Average daily operating hour)	Less than 800 (≤0.5)	More 800 Less 1600 (≤1)	More 1600 Less 3200 (≤2)	More 3200 Less 6300 (≤4)	More 6300 Less 12500 (≤8)	More 12500 Less 25000 (≤16)	More than 25000 (16<)
Light load Normally less than 50% of rated load. Seldom at rated load.	100% Load 0% hour 100%	A	A	A	B	C	D	E
Medium load Normally more than 50% and less than 63% of rated load. Sometimes at rated load.	100% Load 0% hour 100%	A	A	B	C	D	E	F
Heavy load Normally more than 63% and less than 80%. Often at rated load.	100% Load 0% hour 100%	A	B	C	D	E	F	F
Extra heavy load Normally more than 80%. Mostly at rated load or nearly rated load.	100% Load 0% hour 100%	B	C	D	E	F	F	F

APPLICATION EXAMPLE OF LIFTING DEVICE CLASS TO VARIOUS CRANE

CRANE TO BE APPLIED	CLASSIFICATION OF LIFTING DEVICE, ETC.
Crane for Electric power generating station use Crane for Disassembly and inspection use	A
Crane for Machine and Erection plant use	A
Crane for general plant	B - D
Overhead travelling crane (with bucket and with magnet)	D - F
General bridge type crane	B - C

HOIST CLASS, ED RATE AND STARTING FREQUENCY

TYPE	CLASS	ED RATIO (%ED)	STARTING FREQUENCY (Time/hour)
R	D	40	240

• Hoist with creep speed (Ex. RMT-1CT and same series)
Hoist class is same class D.
But duty rating is 25% ED and starting frequency is 200 times per hour.

R

R TYPE HOIST

Ordinary Type

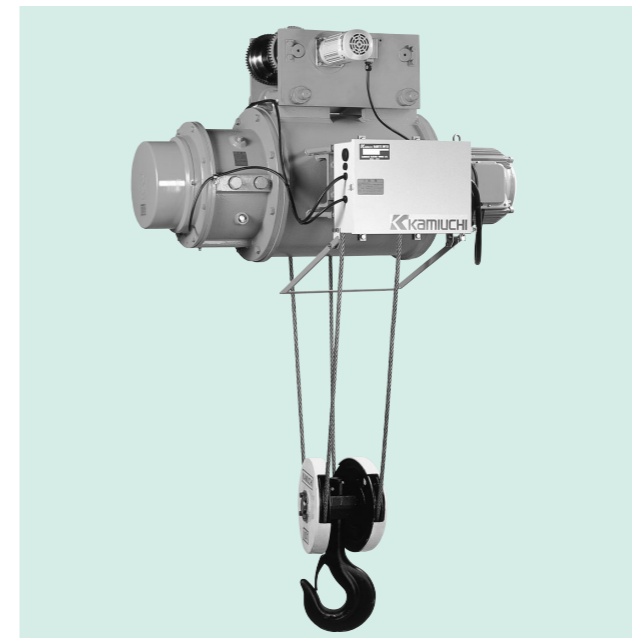

Double Rail Type

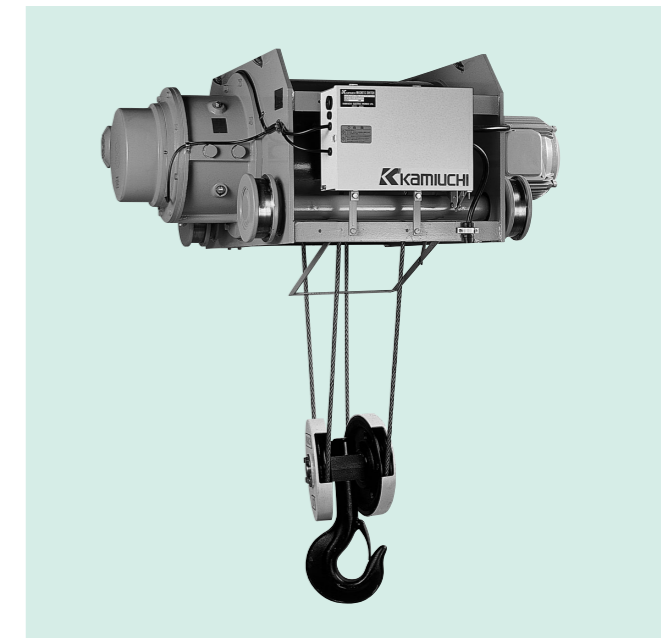

Features

- The totally-enclosed, self-cooled, class F insulation motors, designed for the new series, have high efficiency, high performance, and high torque, and excel in durability.
- All motors are furnished with an external terminal box, and are easy to wire and maintain.
- Made of excellent heat resistant insulating materials, the insulation system is high in reliability, resisting humidity, heat and environment.
- The torque characteristic and starting input characteristic have a sufficient allowance.
- The hoist motor is provided with radiation fin, which keeps the temperature rise to a minimum.
- All the motors are of a low noise type.
- As Trolley brake is equipped with Release device, hoist can be moved under Power supply cut-off condition at the time of installation and maintenance and inspection.
- As Trolley motor is equipped with heat radiator fin and external fan, it can restrain heat increase.

Standard Specification

Power source	Three-phase 200V 50Hz/60Hz, 220V 60Hz, 380V · 400V 50Hz, 400V · 440V 60Hz
Control	Pendant control unit for floor-operation
Rating	60 minute rating
Power feeding method	Electric power shall be supplied to the control panel.
Service temperature	From -10°C to +40°C
Service humidity	90%RH or less (No dew)
Protective structure	Totally enclosed dustproof type
Duty rating	40%ED
Pertinent standards	JIS C 9620 (Electric Hoist) and Japanese Construction
Paint color	Hoist body Munsell 2.5BG6/6.5
	Trolley motor Munsell 2.5PB7/4
	Control box Munsell 5Y7/1
	Sheave cover (Hook block) Munsell 2.5Y8/12(over 5t)
	Sheave cover (Hook block) Munsell 5.5YR6.5/12(below 3t)

Safety device

- Magnet (Electromagnetic) brake
Disc type DC brake is applied for winding-up and trolley.
Lining made from Non-asbestos material with excellent abrasion resistant performance is applied and so can be used for long time without anxiety. Their construction is very simple and easy for the brake gap adjustment. Easy usage and performance are improved remarkably.
- Dual upper limit switch
The control circuit is cut off by the first upper limit switch to stop lifting. In the case of reverse phase operation, reverse winding or short-circuit the second upper limit switch cut off the main circuit, of the hoist motor.
- Load limiter (option)
Overload preventing device through electric current detecting system.
- Power line sensor (option)
Contact-fusion detecting device. Voltage converter will be required, if the power source for main circuit is NOT 3-phase, 200V (50Hz/60Hz). Consult us.
- Thermal unit (option)
Detecting the winding temperature of the motor, this is a safety unit to stop the motor when the temperature exceeds the limit.

Monorail Size (I-beam)

Rated Load	Flange width (mm)	
	500kg · 1t	100 [*] , 125 ^{**} , 150 ^{**}
2t	125 ^{**} , 150, 175 ^{**}	
2.8t · 3t	125 ^{**} , 150, 175 ^{**}	
5t	125 [*] , 150 ^{**} , 175	
7.5t	150, 175 ^{**} , 190 ^{**}	
10t	150, 175 ^{**} , 190 ^{**}	
15t	175 ^{**} , 190	
20t	175 ^{**} , 190	

Flange width in the mark^{**} will be shipped.
If flange width in the ^{*}mark is specified, please let us know before shipment.

Ordinary type

• Motor trolley hoist

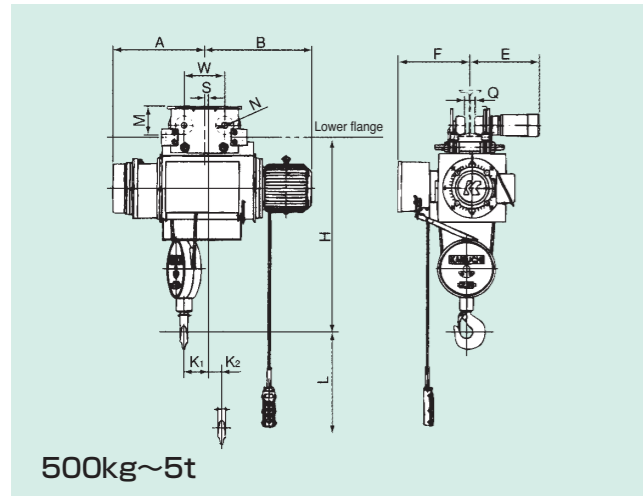

500kg~5t

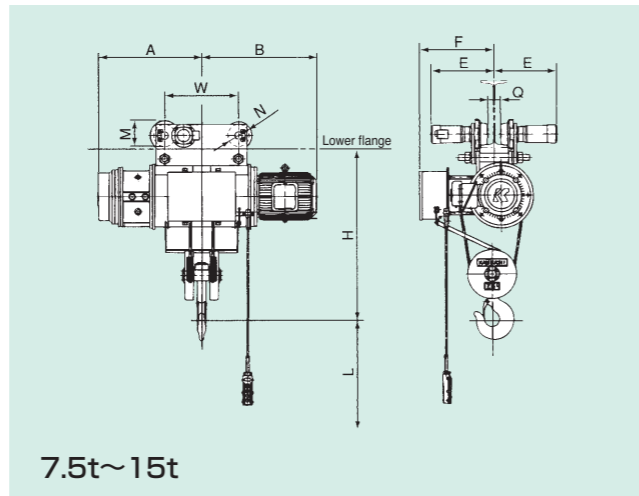

7.5t~15t

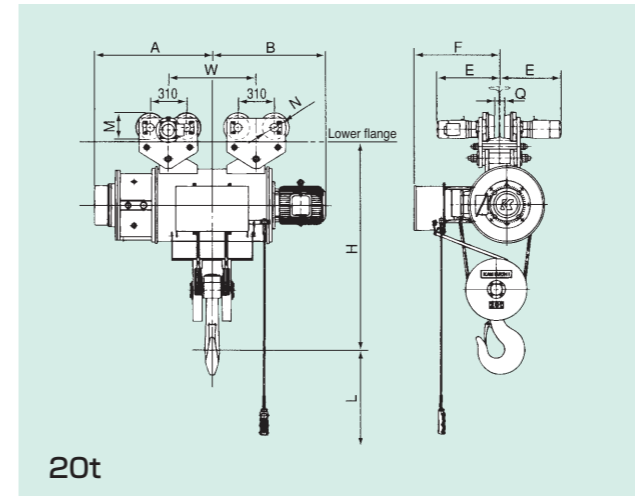

20t

Low headroom type

• Motor trolley hoist

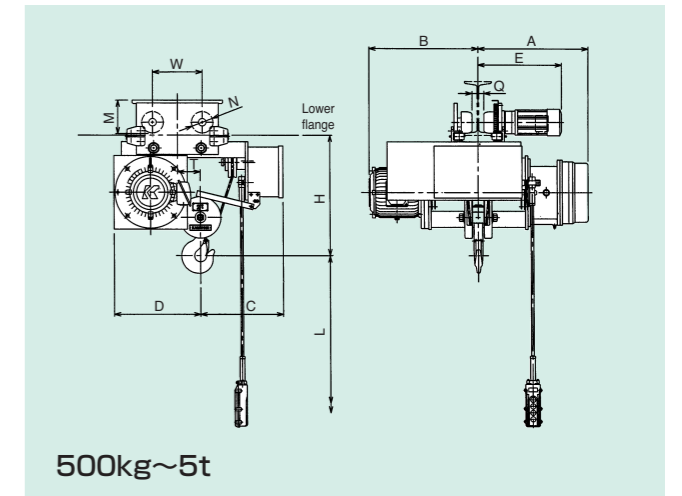

500kg~5t

Specification

Rated Load		500kg		1t		2t		2.8t		3t		5t		7.5t		10t		15t			
Model		RMT-1/2CNN	RMT-1/2CHNN	RMT-1CNN	RMT-1CHNN	RMT-2CNN	RMT-2CHNN	RMT-2.8CNN	RMT-2.8CHNN	RMT-3CNN	RMT-3CHNN	RMT-5CNN	RMT-5CHNN	RMT-7.5CNN	RMT-7.5CHNN	RMT-10CNN	RMT-10CHNN	RMT-15CNN	RMT-15CHNN		
Lifting Height (m)		6	12	6	12	6	12	6	12	6	12	6	12	6	12	6	12	6	12		
Hoist	Hoist Lifting Speed m/s (m/min)	50Hz	0.17 (10)	0.17 (10)	0.13 (7.5)	0.13 (7.5)	0.13 (7.5)	0.13 (7.5)	0.13 (7.5)	0.12 (7)	0.083 (5)	0.075 (4.5)	0.075 (4.5)								
		60Hz	0.20 (12)	0.20 (12)	0.15 (9)	0.15 (9)	0.15 (9)	0.15 (9)	0.14 (8.4)	0.10 (6)	0.092 (5.5)	0.092 (5.5)									
	Hoist Motor	kW	1.5	2.6	3.7	5.3	5.5	9	11	11	18.5										
		Pole	4	4	4	4	4	6	6	4											
Rated Current (A)	200V	50Hz	7.0	11.5	16	24	24	34	48	48	68										
		60Hz	6.6	11.5	16	24	24	34	48	48	68										
		220V	6.6	10.5	15	23	23	32	46	46	64										
Trolley Speed m/s (m/min)	50Hz	0.35 (21)	0.35 (21)	0.35 (21)	0.35 (21)	0.35 (21)	0.35 (21)	0.35 (21)	0.31 (18.5)	0.31 (18.5)											
		60Hz	0.42 (25)	0.42 (25)	0.42 (25)	0.42 (25)	0.42 (25)	0.42 (25)	0.37 (22)	0.37 (22)											
		kW	0.2	0.2	0.4	0.4	0.4	0.75	2×0.4	2×0.4	2×0.75										
Trolley Motor	Pole	4	4	4	4	4	4	4	4	4											
		Rated Current (A)	200V	1.24	1.24	2.35	2.35	2.35	3.88	2×2.35	2×2.35	2×3.88									
			220V	1.09	1.09	2.05	2.05	2.05	3.43	2×2.05	2×2.05	2×3.43									
Wire Rope	Falls	2	2	2	2	2	2	4	4	4											
	Construction	6×W (19)		6×F (29)																	
Approx. Dimensions (mm)	Dia (mm)	L	6000	12000	6000	12000	6000	12000	6000	12000	6000	12000	6000	12000	6000	12000	6000	12000	6000	12000	
		H	680	680	750	750	920	920	1080	1080	1080	1080	1300	1300	1210	1210	1430	1430	1650	1650	
		A	335	405	370	445	430	500	470	560	470	560	560	660	710	910	780	955	935	1135	
		B	325	395	415	540	420	530	465	555	465	555	600	700	800	1000	785	960	875	1075	
		E	355	355	355	355	390	390	390	390	390	390	495	495	430	430	440	440	535	535	
		F	330	330	330	330	365	365	415	415	415	415	475	475	550	550	690	690	750	750	
		K1	40	75	50	125	50	100	55	105	55	105	65	120							
		K2	40	70	50	75	45	75	50	90	50	90	50	100							
		W	190	190	190	190	230	230	230	230	230	230	280	280	500	500	450	450	600	600	
		M	130	130	130	130	155	155	155	155	155	180	180	176	176	176	176	224	224	224	
		N	φ80	φ80	φ80	φ80	φ100	φ100	φ100	φ100	φ100	φ100	φ130	φ130	φ150	φ150	φ150	φ150	φ200	φ200	
		Q	66	66	66	66	50	50	50	50	50	50	74	74	73	73	81	81	72	72	
		S	0	0	0	25	0	20	0	0	0	0									
		Approx. weight (kg)		140	160	170	190	310	360	370	420	370	420	650	690	800	900	1300	1450	2000	2150
		Min. Radius		4mR				3mR				4.5mR		Straight track		Straight track		Straight track			
		Standard I beam width (mm)						125				150		175							

※Dimensions E and Q vary with the rail width.
※Please contact us about your requested curve radius.

Specification

Rated Load		20t		
Model		RMT-20CNN	RMT-20CHNN	
Lifting Height (m)		6	12	
Hoist	Hoist Lifting Speed m/s (m/min)	50Hz	0.075 (4.5)	
		60Hz	0.092 (5.5)	
	Hoist Motor	kW	22	
		Pole	4	
Rated Current (A)	200V	50Hz	86	
		60Hz	86	
		220V	82	
Trolley Speed m/s (m/min)	50Hz	0.31 (18.5)		
		60Hz	0.37 (22)	
		Trolley Motor	kW	2×0.75
Pole	4			
Rated Current (A)	200V	50Hz	2×3.88	
		60Hz	2×3.43	
		220V	2×3.35	
Wire Rope	Falls	4		
	Construction	6×F (29)		
Approx. Dimensions (mm)	Dia (mm)	L	6000	
		H	1750	
		A	1010	
		B	975	
		E	535	
		F	770	
		K1		
		K2		
		W	750	
		M	224	
		N	φ200	
		Q	72	
		Approx. weight (kg)		2150
		Min. Radius		Straight track
		Standard I beam width (mm)		175

※Dimensions E and Q vary with the rail width.
※Please contact us about your requested curve radius.

Specification

Rated Load		500kg		1t		2t		2.8t		3t		5t		
Model		RMT-1/2CLNN	RMT-1CL NN	RMT-1CLH NN	RMT-2CL NN	RMT-2.8CL NN	RMT-2.8CLH NN	RMT-3CL NN	RMT-3CLH NN	RMT-5CLNN				
Lifting Height (m)		6	6	12	6	12	6	12	6	12	6	12	6	
Hoist	Hoist Lifting Speed m/s (m/min)	50Hz	0.17 (10)	0.17 (10)	0.13 (7.5)	0.13 (7.5)	0.13 (7.5)	0.13 (7.5)	0.12 (7)					
		60Hz	0.20 (12)	0.20 (12)	0.15 (9)	0.15 (9)	0.15 (9)	0.15 (9)	0.14 (8.4)					
	Hoist Motor	kW	1.5	2.6	3.7	5.3	5.5	9						
		Pole	4	4	4	4	4	4						
Rated Current (A)	200V	50Hz	7.0	11.5	16	24	24	34						
		60Hz	6.6	11.5	16	24	24	34						
		220V	6.6	10.5	15	23	23	32						
Trolley Speed m/s (m/min)	50Hz	0.35 (21)	0.35 (21)	0.35 (21)	0.35 (21)	0.35 (21)	0.35 (21)	0.35 (21)						
		60Hz	0.42 (25)	0.42 (25)	0.42 (25)	0.42 (25)	0.42 (25)	0.42 (25)						
		kW	0.2	0.2	0.4	0.4	0.4	0.75						
Trolley Motor	Pole	4	4	4	4	4	4							
		Rated Current (A)	200V	1.24	1.24	2.35	2.35	2.35	3.88					
			220V	1.09	1.09	2.05	2.05	2.05	3.43					
Wire Rope	Falls	4	4	4	4	4	4							
	Construction	6×W (19)		6×F (29)										
Approx. Dimensions (mm)	Dia (mm)	L	6000	6000	12000	6000	12000	6000	12000	6000	12000	6000	12000	6000
		H	380	450	450	550	550	650	650	650	650	800		
		A	405	435	570	520	660	560	705	560	705	660		
		B	395	480	615	510	650	555	700	555	700	700		
		E	355	355	355	390	390	390	390	390	390	495		
		C	280	350	350	385	385	410	410	410	410	500		
		D	310	320	320	400	400	440	440	440	440	530		
		W	190	190	190	230	230	230	230	230	230	280		
		M	130	130	130	155	155	155	155	155	155	180		
		N	φ80	φ80	φ80	φ100	φ100	φ100	φ100	φ100	φ100	φ130		
		Q	66	66	66	50	50	50	50	50	50	74		
		T	55	75	75	105	105	110	110	110	110	125		
		Approx. weight (kg)		150	200	230	360	420	430	480	430	480	720	
		Min. Radius		4mR				3mR				4.5mR		
		Standard I beam width (mm)		125										

※Dimensions E and Q vary with the rail width.
※Please contact us about your requested curve radius.

Double rail type

• Motor trolley hoist

R-TYPE INVERTER HOIST

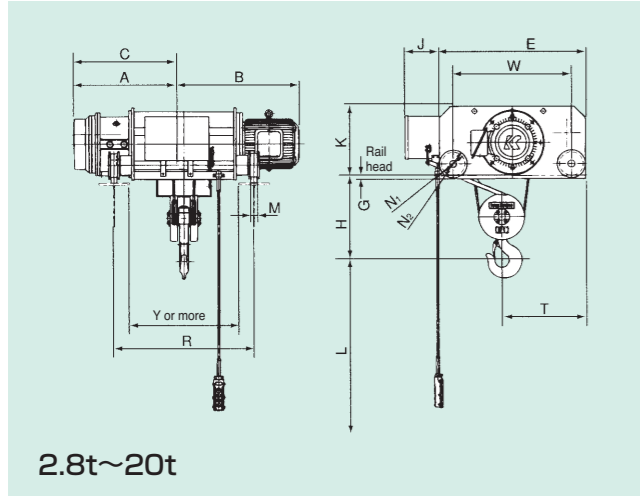

2.8t~20t

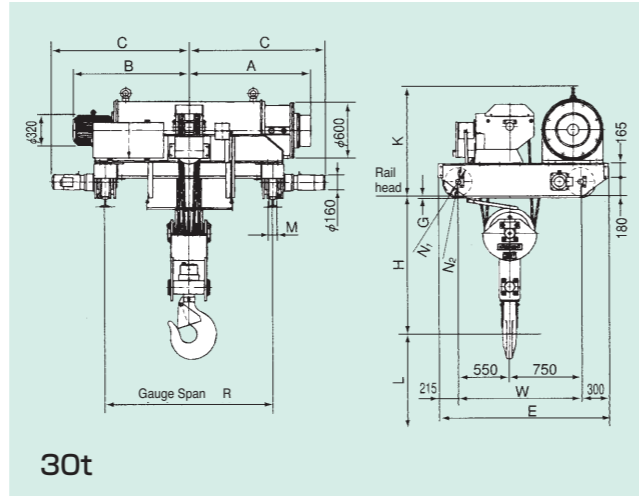

30t

Specification

Rated Load		2.8t		3t		5t		7.5t		10t		15t		20t		30t		
Model		RMT-2.8CDNN	RMT-2.8CDHNN	RMT-3CDNN	RMT-3CDHNN	RMT-5CDNN	RMT-5CDHNN	RMT-7.5CDNN	RMT-7.5CDHNN	RMT-10CDNN	RMT-10CDHNN	RMT-15CDNN	RMT-15CDHNN	RMT-20CDNN	RMT-20CDHNN	RMT-30CDNN	RMT-30CDHNN	
Lifting Height (m)		6	12	6	12	8	12	8	12	8	12	8	12	8	12	8	12	
Hoist	Hoist Lifting Speed m/s (m/min)	50Hz	0.13 (7.5)	0.13 (7.5)	0.12 (7)	0.083 (5)	0.075 (4.5)	0.075 (4.5)	0.075 (4.5)	0.037 (2.2)								
		60Hz	0.15 (9)	0.15 (9)	0.14 (8.4)	0.10 (6)	0.092 (5.5)	0.092 (5.5)	0.092 (5.5)	0.045 (2.7)								
	Hoist Motor	kW	5.3	5.5	9	11	11	18.5	22	18.5								
		Pole	4	4	4	6	6	4	4	4								
Trolley	Trolley Speed m/s (m/min)	50Hz	0.35 (21)	0.35 (21)	0.35 (21)	0.35 (21)	0.31 (18.5)	0.31 (18.5)	0.31 (18.5)	0.31 (18.5)	0.37 (22)	0.37 (22)	0.37 (22)	0.37 (22)	0.37 (22)	0.37 (22)	0.37 (22)	0.37 (22)
		60Hz	0.42 (25)	0.42 (25)	0.42 (25)	0.42 (25)	0.37 (22)	0.37 (22)	0.37 (22)	0.37 (22)	0.37 (22)	0.37 (22)	0.37 (22)	0.37 (22)	0.37 (22)	0.37 (22)	0.37 (22)	0.37 (22)
		kW	0.4	0.4	0.75	0.75	0.75	1.5	1.5	2×1.5								
Rated Current (A)	200V 50Hz	24	24	34	48	48	68	86	86	68	68	86	86	68	68	68	68	
	200V 60Hz	24	24	34	48	48	68	86	86	68	68	86	86	68	68	68	68	
	220V 60Hz	23	23	32	46	46	64	82	82	64	64	82	82	64	64	64	64	
Rated Current (A)	200V 50Hz	2.35	2.35	3.88	3.88	3.88	6.97	6.97	6.97	2×6.97								
	200V 60Hz	2.05	2.05	3.43	3.43	3.43	6.29	6.29	6.29	2×6.29								
	220V 60Hz	2.02	2.02	3.35	3.35	3.35	6.00	6.00	6.00	2×6.00								
Wire Rope	Falls	4	4	4	4	4	4	4	4	4	4	4	4	4	4	4	8	
	Construction	6×Fi (29)																
Approx. Dimensions (mm)	L	6000	12000	6000	12000	8000	12000	8000	12000	8000	12000	8000	12000	8000	12000	8000	12000	
	H	450	450	450	450	540	540	660	660	680	680	800	800	950	950	1450	1450	
	A	560	705	560	705	710	810	810	910	830	955	1010	1135	1135	1235	1315	1515	
	B	555	700	555	700	750	850	900	1000	835	960	950	1075	1100	1200	1250	1450	
	C	555	700	555	700	715	815									1465	1665	
	E	780	780	780	780	930	930	950	950	1230	1230	1250	1250	1250	1250	1815	1815	
	K	380	380	380	380	440	440	470	470	630	630	680	680	680	680	1150	1150	
	W	600	600	600	600	750	750	750	750	950	950	1000	1000	1000	1000	1300	1300	
	J	200	200	200	200	225	225	225	225	225	225	260	260	280	280			
	T	450	450	450	450	535	535	540	540	665	665	690	690	690	690			
	R	650	900	650	900	900	1150	1150	1300	900	1150	1150	1400	1400	1600	1800	2200	
	Y	400	700	400	700	560	760	750	950	600	850	790	1040	1040	1240			
	M	45	45	45	45	45	45	45	45	45	45	56	56	56	56	80	80	
	G	15	15	15	15	20	20	20	20	20	20	20	20	20	20	20	20	
	N1	φ150	φ150	φ150	φ150	φ150	φ150	φ150	φ150	φ200	φ200	φ200	φ200	φ200	φ200	φ300	φ300	
	N2	φ178	φ178	φ178	φ178	φ178	φ178	φ178	φ178	φ230	φ230	φ230	φ230	φ230	φ230	φ340	φ340	
Approx. weight (kg)		430	480	430	480	720	780	850	900	1400	1550	2100	2200	2250	2350	3800	4050	

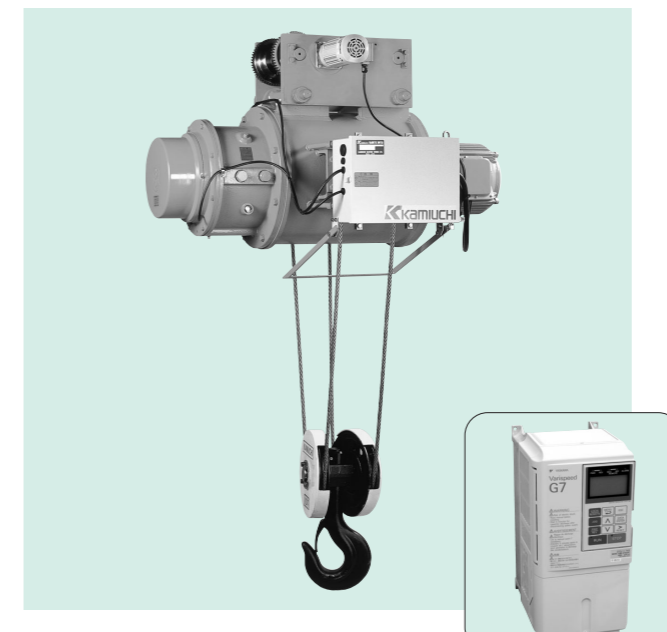

Standard Specification

Power source	Three-phase 200V 50Hz/60Hz, 220V 60Hz, 380V 50Hz (380V · 400V 50Hz, 400V · 440V 60Hz)
Control	Pendant control unit for floor-operation (two-step push-in method)
Duty rating	40%ED
Service temperature	From -10°C to +40°C
Humidity	90%RH (not to condense dew)
Atmosphere	Free from corrosive gas, low dust level
Control method	Inverter drive
Power feeding method	Cable power feeding Hoist-up inverter can be supplied from trolley (tandem collector) However, momentary power failure of over 10 msec should not occur
Protective structure	Dustproof type
Pertinent standards	JIS C 9620 (Electric Hoists) and Japanese Construction Codes for Crane

Hoist Class, ED Rate and Starting Frequency

TYPE	CLASS	ED RATIO (%ED)	STARTING FREQUENCY (Time/hour)
R	D	40	240

• Hoist with creep speed (Ex. RMT-1CT and same series)
Hoist class is same class D.
But duty rating is 25% ED and starting frequency is 200 times per hour.

Special Features

- The most suitable speed can be selected.
The winding UP/DOWN speed can be set in the range of 1-1/10 speed ratio.
The painting and galvanizing line works can be made at the most suitable speed and so the uniformization of the products can be achieved.
- Small shock to the load.
※ In case of free run stop (Standard) control.
Smooth start and no shock at the time of speed change.
※ In case of the speed reducing stop (Semi standard) control.
Smooth start and stop and no shock. Also, no shock at the time of speed change.

- Safety design of the built-in protection circuit.
Many protection circuits are built in and so very safety for various abnormality.
Also, the digital operator showing the contents of damages can make quick maintenance.
- Small electric power.
Inverter output suitable for motor by sensorless vector control and so no excess current at the time of low speed.
※ In case of standard model, the inverter control is only for winding up.
Regarding the inverter control of travelling and (winding up + travelling), please consult with us.
※ As option, the load limiter function and the right load speed up function are prepared.
Also, small electric power by small starting current at the time of start compared with commercial use.

Operation Pattern

FREE RUN STOP (STANDARD)

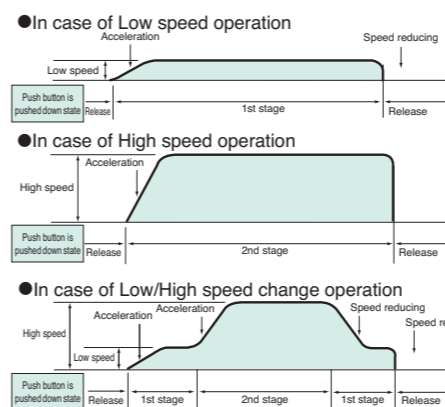

SPEED REDUCING STOP (SEMI STANDARD)

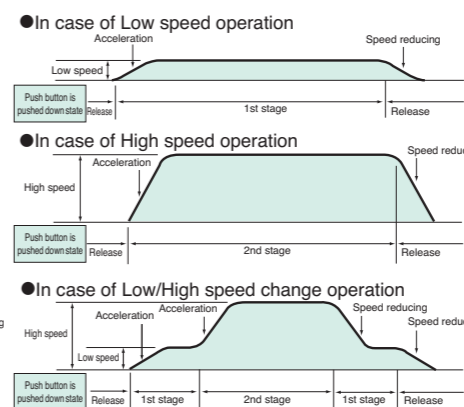

※ In case of speed reducing operation, the operation is continued due to reducing the speed by the inverter after releasing the push button.
※ The above speed reducing stop is standard for travelling.

Inverter

The inverter converts 3 phase Alternating current voltage to Direct current voltage by the diode bridge and change the rotation speed of the electric motor through the variable controlling of the frequency of the voltage to be charged to the power transistor with the micro computer (CPU).
Change the frequency in order to change the rotation speed of the induction electric motor.

FORMULA TO FIGURE OUT THE NUMBER OF ROTATION

$$N = (120 F/P) (1-S)$$

N : Rotation speed (rpm)
F : Frequency (Hz)
P : Number of pole
S : Slip (%)

Ordinary type

• Motor trolley hoist

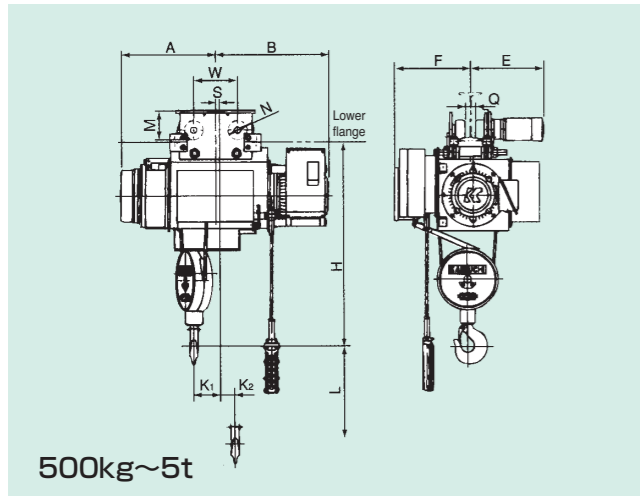

500kg~5t

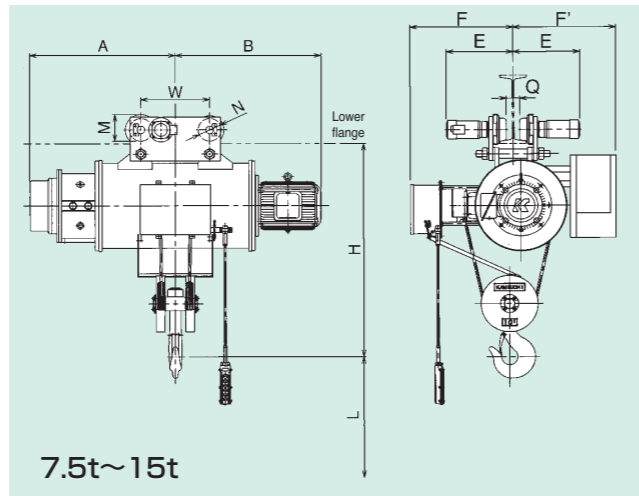

7.5t~15t

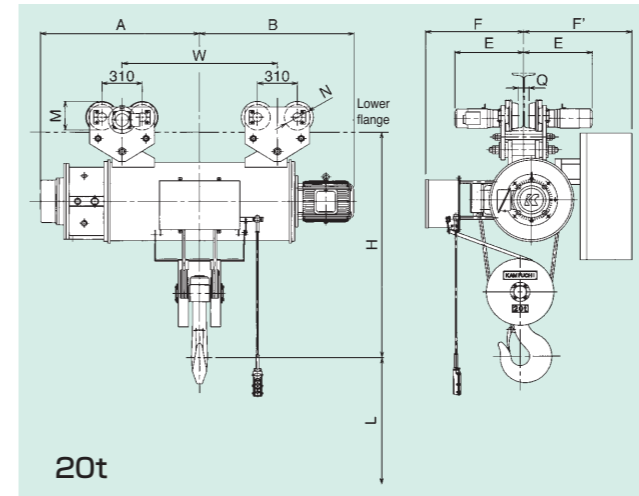

20t

Low headroom type

• Motor trolley hoist

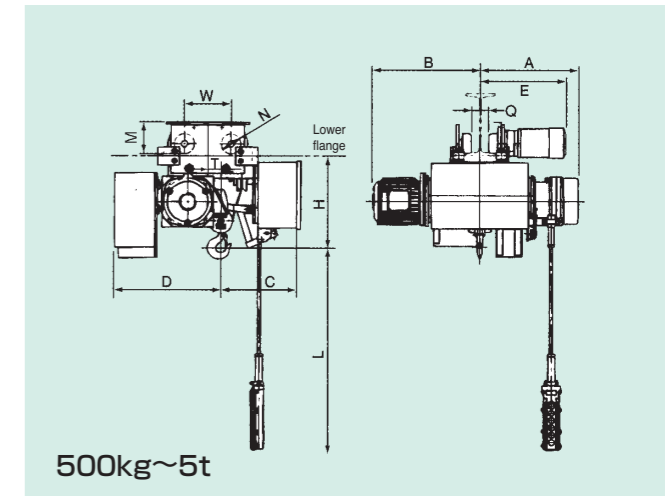

500kg~5t

Specification

Rated Load		500kg		1t		2t		2.8t		3t		5t		7.5t		10t		15t		
Model		RMT-1/2CVN	RMT-1/2CHVN	RMT-1CVN	RMT-1CHVN	RMT-2CVN	RMT-2CHVN	RMT-2.8CVN	RMT-2.8CHVN	RMT-3CVN	RMT-3CHVN	RMT-5CVN	RMT-5CHVN	RMT-7.5CVN	RMT-7.5CHVN	RMT-10CVN	RMT-10CHVN	RMT-15CVN	RMT-15CHVN	
Lifting Height (m)		6	12	6	12	6	12	6	12	6	12	6	12	6	12	6	12	6	12	
Hoist	Hoist Lifting Speed m/s (m/min)	50Hz	0.017-0.17 (1.0-10)		0.017-0.17 (1.0-10)		0.013-0.13 (0.8-7.5)		0.013-0.13 (0.8-7.5)		0.013-0.13 (0.8-7.5)		0.012-0.12 (0.7-7)		0.0083-0.083 (0.5-5)		0.0067-0.075 (0.4-4.5)		0.0067-0.075 (0.4-4.5)	
		60Hz	0.020-0.20 (1.2-12)		0.020-0.20 (1.2-12)		0.015-0.15 (0.9-9)		0.015-0.15 (0.9-9)		0.015-0.15 (0.9-9)		0.013-0.14 (0.8-8.4)		0.010-0.10 (0.6-6)		0.0083-0.092 (0.5-5.5)		0.0083-0.092 (0.5-5.5)	
	Hoist Motor	kW	1.5		2.6		3.7		5.3		5.5		9		11		11		18.5	
		Pole	4		4		4		4		4		4		6		6		4	
Rated Current (A)	200V	50Hz	7.0		11.5		16.0		24		24		34		48		48		68	
		60Hz	6.6		11.5		16.0		24		24		34		48		48		68	
		220V	6.6		10.5		15.0		23		23		32		46		46		64	
Trolley Speed m/s (m/min)	50Hz	0.35 (21)		0.35 (21)		0.35 (21)		0.35 (21)		0.35 (21)		0.35 (21)		0.35 (21)		0.31 (18.5)		0.31 (18.5)		
		0.42 (25)		0.42 (25)		0.42 (25)		0.42 (25)		0.42 (25)		0.42 (25)		0.42 (25)		0.37 (22)		0.37 (22)		
		Trolley Motor	kW	0.2		0.2		0.4		0.4		0.4		0.75		2×0.4		2×0.4		2×0.75
Pole	4		4		4		4		4		4		4		4		4			
Rated Current (A)	200V	50Hz	1.24		1.24		2.35		2.35		2.35		3.88		2×2.35		2×2.35		2×3.88	
		60Hz	1.09		1.09		2.05		2.05		2.05		3.43		2×2.05		2×2.05		2×3.43	
		220V	1.09		1.09		2.02		2.02		2.02		3.35		2×2.02		2×2.02		2×3.35	
Wire Rope	Falls	2		2		2		2		2		2		4		4		4		
	Construction	6×W (19)		8		10		12.5		12.5		16		14		16		20		
Approx. Dimensions (mm)	L	6000	12000	6000	12000	6000	12000	6000	12000	6000	12000	6000	12000	6000	12000	6000	12000	6000	12000	
	H	680	680	750	750	920	920	1080	1080	1080	1080	1300	1300	1210	1210	1430	1430	1650	1650	
	A	335	405	370	445	430	500	470	560	470	560	560	660	710	910	780	955	935	1135	
	B	580	580	580	580	580	580	580	580	580	580	600	700	800	1000	785	960	875	1075	
	E	355	355	355	355	390	390	390	390	390	390	495	495	430	430	440	440	535	535	
	F	360	360	360	360	395	395	420	420	420	420	475	475	550	550	690	690	750	750	
	F'													590	590	670	670	740	740	
	K1	40	75	50	125	50	100	55	105	55	105	65	120							
	K2	40	70	50	75	45	75	50	90	50	90	50	100							
	W	190	190	190	190	230	230	230	230	230	230	280	280	500	500	450	450	600	600	
	M	130	130	130	130	155	155	155	155	155	155	180	180	176	176	176	176	224	224	
	N	φ80	φ80	φ80	φ80	φ100	φ100	φ100	φ100	φ100	φ100	φ100	φ100	φ130	φ130	φ150	φ150	φ200	φ200	
	Q	66	66	66	66	50	50	50	50	50	50	74	74	73	73	81	81	72	72	
	S	0	0	0	25	0	20	0	0	0	0	0	0							
	Approx. weight (kg)		170	180	190	210	340	400	400	450	400	450	730	770	850	950	1450	1600	2150	2300
	Min. Radius		4mR				3mR				4.5mR		Straight track		Straight track		Straight track			
	Standard I beam width (mm)						125				150		175							

※Dimensions E and Q vary with the rail width.
※Please contact us about your requested curve radius.

Specification

Rated Load		20t		
Model		RMT-20CVN	RMT-20CHVN	
Lifting Height (m)		6	12	
Hoist	Hoist Lifting Speed m/s (m/min)	50Hz	0.0067-0.075 (0.4-4.5)	
		60Hz	0.0083-0.092 (0.5-5.5)	
	Hoist Motor	kW	22	
		Pole	4	
Rated Current (A)	200V	50Hz	86	
		60Hz	86	
		220V	82	
Trolley Speed m/s (m/min)	50Hz	0.31 (18.5)		
		0.37 (22)		
	Trolley Motor	kW	2×0.75	
Pole		4		
Rated Current (A)	200V	50Hz	2×3.88	
		60Hz	2×3.43	
		220V	2×3.35	
Wire Rope	Falls	4		
	Construction	6×Fi (29)		
Approx. Dimensions (mm)	L	6000	12000	
	H	1750	1750	
	A	1010	1235	
	B	975	1200	
	E	535	535	
	F	770	770	
	F'	800	800	
	K1			
	K2			
	W	750	1200	
	M	224	224	
	N	φ200	φ200	
	Q	72	72	
	Approx. weight (kg)		2300	2450
	Min. Radius		Straight track	
	Standard I beam width (mm)		175	

※Dimensions E and Q vary with the rail width.
※Please contact us about your requested curve radius.

Specification

Rated Load		500kg		1t		2t		2.8t		3t		5t		
Model		RMT-1/2 CLVN	RMT-1 CLVN	RMT-1 CHVN	RMT-2 CLVN	RMT-2 CHVN	RMT-2.8 CLVN	RMT-2.8 CHVN	RMT-3 CLVN	RMT-3 CHVN	RMT-5 CLVN			
Lifting Height (m)		6	6	12	6	12	6	12	6	12	6	6		
Hoist	Hoist Lifting Speed m/s (m/min)	50Hz	0.017-0.17 (1.0-10)		0.017-0.17 (1.0-10)		0.013-0.13 (0.8-7.5)		0.013-0.13 (0.8-7.5)		0.013-0.13 (0.8-7.5)		0.012-0.12 (0.7-7)	
		60Hz	0.020-0.20 (1.2-12)		0.020-0.20 (1.2-12)		0.015-0.15 (0.9-9)		0.015-0.15 (0.9-9)		0.015-0.15 (0.9-9)		0.013-0.14 (0.8-8.4)	
	Hoist Motor	kW	1.5		2.6		3.7		5.3		5.5		9	
		Pole	4		4		4		4		4		4	
Rated Current (A)	200V	50Hz	7.0		11.5		16		24		24		34	
		60Hz	6.6		11.5		16		24		24		34	
		220V	6.6		10.5		15		23		23		32	
Trolley Speed m/s (m/min)	50Hz	0.35 (21)		0.35 (21)		0.35 (21)		0.35 (21)		0.35 (21)		0.35 (21)		
		0.42 (25)		0.42 (25)		0.42 (25)		0.42 (25)		0.42 (25)		0.42 (25)		
	Trolley Motor	kW	0.2		0.2		0.4		0.4		0.4		0.75	
Pole		4		4		4		4		4		4		
Rated Current (A)	200V	50Hz	1.24		1.24		2.35		2.35		2.35		3.88	
		60Hz	1.09		1.09		2.05		2.05		2.05		3.43	
		220V	1.09		1.09		2.02		2.02		2.02		3.35	
Wire Rope	Falls	4		4		4		4		4		4		
	Construction	6×W (19)		8		10		12.5		12.5		16		
Approx. Dimensions (mm)	L	6000	6000	12000	6000	12000	6000	12000	6000	12000	6000	12000	6000	
	H	380	450	450	550	550	650	650	650	650	650	650	800	
	A	405	435	570	520	660	560	705	560	705	560	705	660	
	B	395	480	615	510	650	555	700	555	700	555	700	700	
	E	355	355	355	390	390	390	390	390	390	390	390	495	
	F	340	380	420	430	430	430	430	430	430	430	430	530	
	D	510	510	570	670	670	670	670	670	670	670	670	810	
	W	190	190	190	230	230	230	230	230	230	230	230	280	
	M	130	130	130	155	155	155	155	155	155	155	155	180	
	N	φ80	φ80	φ80	φ100	φ100	φ100	φ100	φ100	φ100	φ100	φ100	φ130	
	Q	66	66	66	50	50	50	50	50	50	50	50	74	
	T	55	75	75	105	105	110	110	110	110	110	110	125	
	Approx. weight (kg)		170	220	250	390	450	460	510	460	510	770		
	Min. Radius		4mR				3mR				4.5mR			
	Standard I beam width (mm)						125				150			

※Dimensions E and Q vary with the rail width.
※Please contact us about your requested curve radius.

Double rail type

• Motor trolley hoist

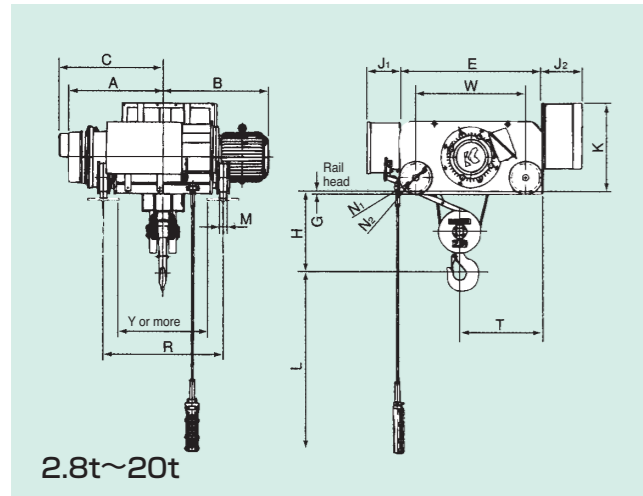

2.8t~20t

Specification

Rated Load		2.8t		3t		5t		7.5t		10t		15t		20t		
Model		RMT-2.8CDVN	RMT-2.8CDHVN	RMT-3CDVN	RMT-3CDHVN	RMT-5CDVN	RMT-5CDHVN	RMT-7.5CDVN	RMT-7.5CDHVN	RMT-10CDVN	RMT-10CDHVN	RMT-15CDVN	RMT-15CDHVN	RMT-20CDVN	RMT-20CDHVN	
Lifting Height (m)		6	12	6	12	8	12	8	12	8	12	8	12	8	12	
Hoist	Lifting Speed m/s (m/min)	50Hz	0.013-0.13 (0.8-7.5)		0.013-0.13 (0.8-7.5)		0.012-0.12 (0.7-7)		0.0083-0.083 (0.5-5)		0.0067-0.075 (0.4-4.5)		0.0067-0.075 (0.4-4.5)		0.0067-0.075 (0.4-4.5)	
		60Hz	0.015-0.15 (0.9-9)		0.015-0.15 (0.9-9)		0.013-0.14 (0.8-8.4)		0.010-0.10 (0.6-6)		0.0083-0.092 (0.5-5.5)		0.0083-0.092 (0.5-5.5)		0.0083-0.092 (0.5-5.5)	
Hoist Motor	Power	5.3		5.5		9		11		11		18.5		22		
	Pole	4		4		4		6		6		4		4		
Rated Current (A)	200V 50Hz	24		24		34		48		48		68		86		
	200V 60Hz	24		24		34		48		48		68		86		
	220V 60Hz	23		23		32		46		46		64		82		
Trolley Speed m/s (m/min)	50Hz	0.35 (21)		0.35 (21)		0.35 (21)		0.35 (21)		0.31 (18.5)		0.31 (18.5)		0.31 (18.5)		
	60Hz	0.42 (25)		0.42 (25)		0.42 (25)		0.42 (25)		0.37 (22)		0.37 (22)		0.37 (22)		
Trolley Motor	Power	0.4		0.4		0.75		0.75		0.75		1.5		1.5		
	Pole	4		4		4		4		4		4		4		
Rated Current (A)	200V 50Hz	2.35		2.35		3.88		3.88		3.88		6.97		6.97		
	200V 60Hz	2.05		2.05		3.43		3.43		3.43		6.29		6.29		
	220V 60Hz	2.02		2.02		3.35		3.35		3.35		6.00		6.00		
Wire Rope	Falls	4		4		4		4		4		4		4		
	Construction Dia (mm)	9		9		11.2		14		16		20		22.4		
Approx. Dimensions (mm)	L	6000	12000	6000	12000	8000	12000	8000	12000	8000	12000	8000	12000	8000	12000	
	H	450	450	450	450	540	540	660	660	680	680	800	800	950	950	
	A	560	705	560	705	710	810	810	910	830	955	1010	1135	1135	1235	
	B	555	700	555	700	750	850	900	1000	835	960	950	1075	1100	1200	
	C	555	700	555	700	715	815									
	E	780	780	780	780	930	930	950	950	1230	1230	1250	1250	1250	1250	
	K	480	480	480	480	650	650	650	650	700	700	850	850	1000	1000	
	W	600	600	600	600	750	750	750	750	950	950	1000	1000	1000	1000	
	J1	200	200	200	200	225	225	225	225	225	225	260	260	280	280	
	J2	220		220		280		280		280		310		370		
	T	450	450	450	450	535	535	540	540	665	665	690	690	690	690	
	R	650	900	650	900	900	1150	1150	1300	900	1150	1150	1400	1400	1600	
	Y	400	700	400	700	560	760	750	950	600	850	790	1040	1040	1240	
	M	45	45	45	45	45	45	45	45	45	45	56	56	56	56	
	G	15	15	15	15	20	20	20	20	20	20	20	20	20	20	
	N1	φ150	φ150	φ150	φ150	φ150	φ150	φ150	φ150	φ200	φ200	φ200	φ200	φ200	φ200	
	N2	φ178	φ178	φ178	φ178	φ178	φ178	φ178	φ178	φ230	φ230	φ230	φ230	φ230	φ230	
Approx. weight (kg)	450		500		450		500		770		830		950		1000	

Creep speed Ordinary type

• Motor trolley hoist

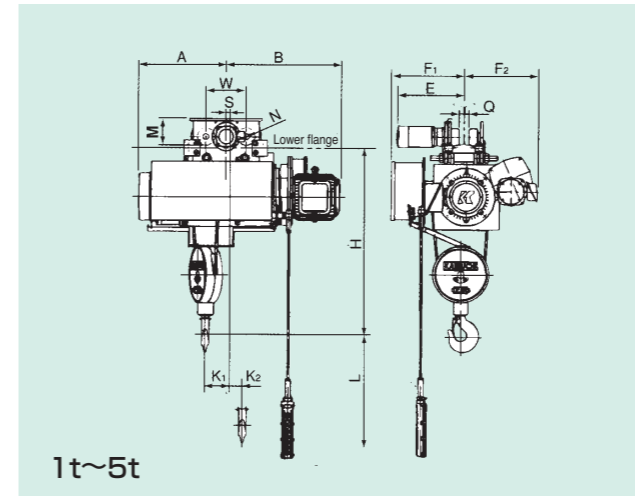

1t~5t

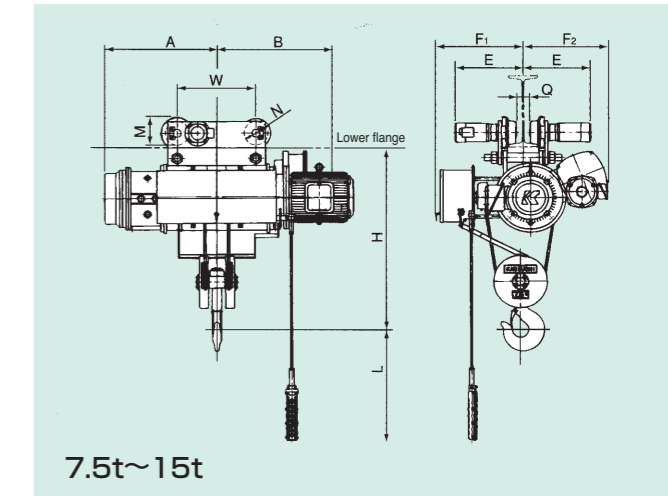

7.5t~15t

Specification

Rated Load		1t		2t		2.8t		3t		5t		7.5t		10t		15t				
Model		RMT-1CTN	RMT-1CHTN	RMT-2CTN	RMT-2CHTN	RMT-2.8CTN	RMT-2.8CHTN	RMT-3CTN	RMT-3CHTN	RMT-5CTN	RMT-5CHTN	RMT-7.5CTN	RMT-7.5CHTN	RMT-10CTN	RMT-10CHTN	RMT-15CTN	RMT-15CHTN			
Lifting Height (m)		6	12	6	12	6	12	6	12	6	12	6	12	6	12	6	12			
Hoist	Lifting Speed m/s (m/min)	50Hz	0.17 (10)		0.13 (7.5)		0.13 (7.5)		0.13 (7.5)		0.12 (7)		0.083 (5)		0.075 (4.5)		0.075 (4.5)			
		60Hz	0.20 (12)		0.15 (9)		0.15 (9)		0.15 (9)		0.14 (8.4)		0.10 (6)		0.092 (5.5)		0.092 (5.5)			
Hoist Motor	Power	2.6		3.7		5.3		5.5		9		11		11		18.5				
	Pole	4		4		4		4		4		4		4		4				
Rated Current (A)	200V 50Hz	0.017 (1.0)		0.013 (0.75)		0.013 (0.75)		0.013 (0.75)		0.012 (0.7)		0.0083 (0.5)		0.0075 (0.45)		0.0075 (0.45)				
	200V 60Hz	0.020 (1.2)		0.015 (0.9)		0.015 (0.9)		0.015 (0.9)		0.014 (0.84)		0.010 (0.6)		0.0092 (0.55)		0.0092 (0.55)				
	220V 60Hz	0.75		0.75		0.75		0.75		1.5		1.1		1.8		2.6				
Trolley Speed m/s (m/min)	50Hz	0.35 (21)		0.35 (21)		0.35 (21)		0.35 (21)		0.35 (21)		0.35 (21)		0.31 (18.5)		0.31 (18.5)				
	60Hz	0.42 (25)		0.42 (25)		0.42 (25)		0.42 (25)		0.42 (25)		0.42 (25)		0.37 (22)		0.37 (22)				
Trolley Motor	Power	0.2		0.4		0.4		0.4		0.75		2×0.4		2×0.4		2×0.75				
	Pole	4		4		4		4		4		4		4		4				
Rated Current (A)	200V 50Hz	2.35		2.35		3.88		3.88		6.97		6.97		6.97		6.97				
	200V 60Hz	2.05		2.05		3.43		3.43		6.29		6.29		6.29		6.29				
	220V 60Hz	2.02		2.02		3.35		3.35		6.00		6.00		6.00		6.00				
Wire Rope	Falls	4		4		4		4		4		4		4		4				
	Construction Dia (mm)	9		9		11.2		14		16		20		22.4		22.4				
Approx. Dimensions (mm)	L	6000	12000	6000	12000	8000	12000	8000	12000	8000	12000	8000	12000	8000	12000	8000	12000			
	H	450	450	450	450	540	540	660	660	680	680	800	800	950	950	950	950			
	A	560	705	560	705	710	810	810	910	830	955	1010	1135	1135	1235	1235	1235			
	B	555	700	555	700	750	850	900	1000	835	960	950	1075	1100	1200	1200	1200			
	C	555	700	555	700	715	815													
	E	780	780	780	780	930	930	950	950	1230	1230	1250	1250	1250	1250	1250	1250			
	K	480	480	480	480	650	650	650	650	700	700	850	850	1000	1000	1000	1000			
	W	600	600	600	600	750	750	750	750	950	950	1000	1000	1000	1000	1000	1000			
	F1	370	370	405	405	425	425	425	425	500	500	575	575	720	720	770	770			
	F2	385	385	440	440	440	440	440	440	510	510	540	540	550	550	560	560			
	K1	50	125	50	100	55	105	55	105	65	120									
	K2	50	75	45	75	50	90	50	90	50	100									
	W	190	190	230	230	230	230	230	230	280	280	500	500	450	450	600	600			
	M	130	130	155	155	155	155	155	155	180	180	176	176	176	176	224	224			
	N	φ80	φ80	φ100	φ100	φ100	φ100	φ100	φ100	φ130	φ130	φ150	φ150	φ150	φ150	φ200	φ200			
	Q	66	66	50	50	50	50	50	50	74	74	73	73	81	81	72	72			
	S	0	25	0	20	0	0	0	0											
Approx. weight (kg)	210		260		360		440		450		530		450		530		830			
Min. Radius	4mR				3mR				4.5mR				Straight track				Straight track			
Standard I beam width (mm)	125				150				175				175				175			

※Dimensions E and Q vary with the rail width.
 ※Please contact us about your requested curve radius.

Creep speed
Low headroom type • Motor trolley hoist

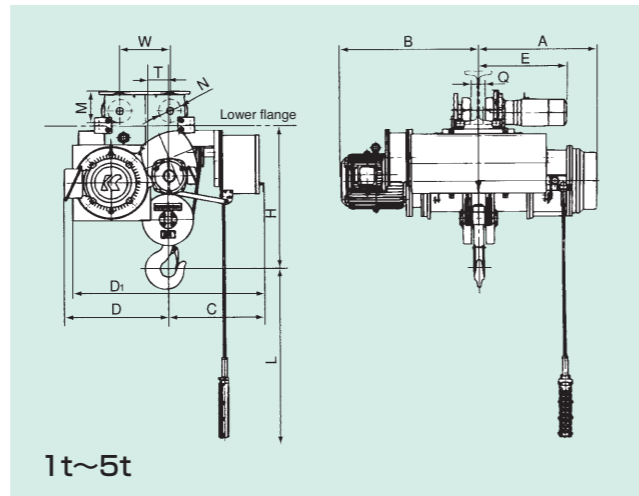
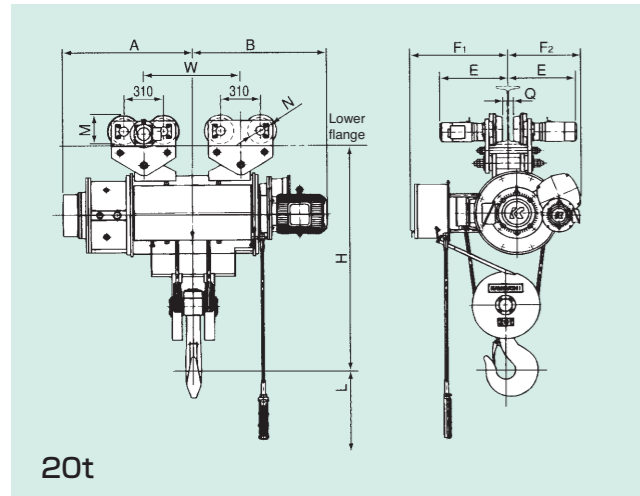

Creep speed
Double rail type • Motor trolley hoist

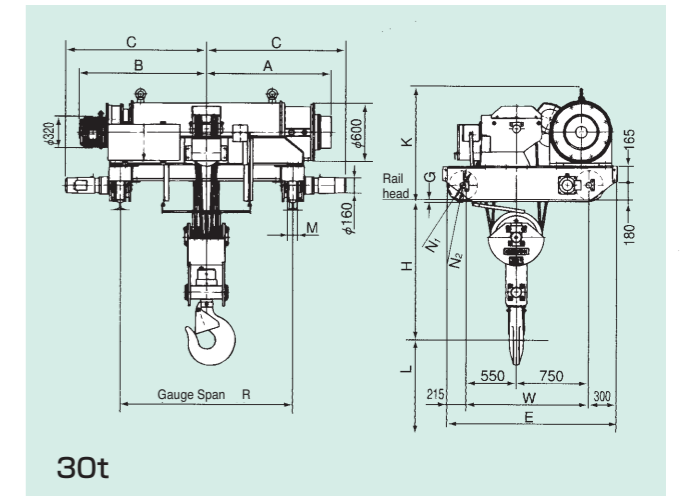
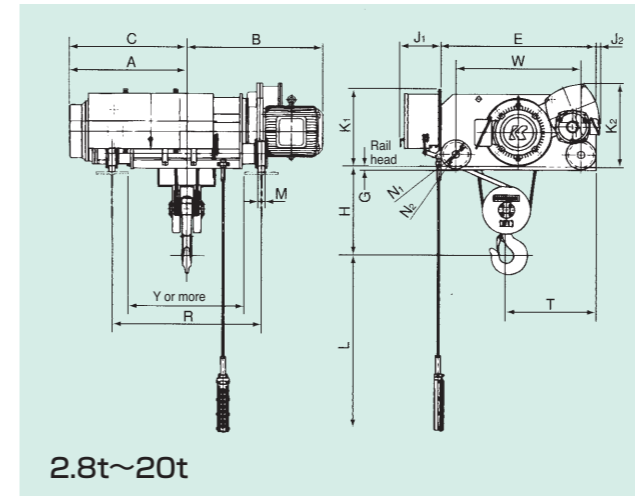

● Specification

Rated Load		20t	
Model		RMT-20CTN	RMT-20CHTN
Lifting Height (m)		6	12
Hoist Lifting Speed m/s (m/min)	50Hz	0.075 (4.5)	
	60Hz	0.092 (5.5)	
Hoist Motor		22	
Hoist Lifting Speed m/s (m/min)	50Hz	0.0075 (0.45)	
	60Hz	0.0092 (0.55)	
Hoist Motor		2.6	
Trolley Speed m/s (m/min)	50Hz	0.31 (18.5)	
	60Hz	0.37 (22)	
Hoist Motor		2×0.75	
Wire Rope	Falls	4	
	Construction	6×Fi (29)	
Approx. Dimensions (mm)	L	6000	12000
	H	1750	1750
A	1010	1235	
B	1055	1280	
E	535	535	
F1	790	790	
F2	560	560	
K1			
K2			
W	750	1200	
M	224	224	
N	φ200	φ200	
Q	72	72	
Approx. weight (kg)		2350	2500
Min. Radius		Straight track	
Standard I beam width (mm)		175	

※ Dimensions E and Q vary with the rail width.
※ Please contact us about your requested curve radius.

● Specification

Rated Load		1t	2t	2.8t	3t	5t
Model		RMT-1 CLTN	RMT-2 CLTN	RMT-2.8 CLTN	RMT-3 CLTN	RMT-5 CLTN
Lifting Height (m)		6	12	6	12	6
Hoist Lifting Speed m/s (m/min)	50Hz	0.17 (10)	0.13 (7.5)	0.13 (7.5)	0.13 (7.5)	0.12 (7)
	60Hz	0.20 (12)	0.15 (9)	0.15 (9)	0.15 (9)	0.14 (8.4)
Hoist Motor		2.6	3.7	5.3	5.5	9
Hoist Lifting Speed m/s (m/min)	50Hz	0.017 (1.0)	0.013 (0.75)	0.013 (0.75)	0.013 (0.75)	0.012 (0.7)
	60Hz	0.020 (1.2)	0.015 (0.9)	0.015 (0.9)	0.015 (0.9)	0.014 (0.84)
Hoist Motor		0.75	0.75	0.75	0.75	1.5
Trolley Speed m/s (m/min)	50Hz	0.35 (21)	0.35 (21)	0.35 (21)	0.35 (21)	0.35 (21)
	60Hz	0.42 (25)	0.42 (25)	0.42 (25)	0.42 (25)	0.42 (25)
Hoist Motor		0.2	0.4	0.4	0.4	0.75
Wire Rope	Falls	4	4	4	4	4
	Construction	6×W (19)		6×Fi (29)		
Approx. Dimensions (mm)	L	6000	12000	6000	12000	6000
	H	450	450	550	550	650
A	435	570	520	660	560	
B	575	710	620	760	615	
E	355	355	390	390	390	
Q	66	66	50	50	50	
D1	320	320	400	400	440	
D2	355	355	425	425	495	
W	190	190	230	230	230	
M	130	130	155	155	155	
N	φ80	φ80	φ100	φ100	φ100	
C	390	390	420	420	420	
T	75	75	105	105	110	
Approx. weight (kg)		290	340	450	530	600
Min. Radius		4mR		3mR		4.5mR
Standard I beam width (mm)				125		150

※ Dimensions E and Q vary with the rail width.
※ Please contact us about your requested curve radius.

● Specification

Rated Load		2.8t	3t	5t	7.5t	10t	15t	20t	30t
Model		RMT-2.8CDTN	RMT-3CDTN	RMT-5CDTN	RMT-7.5CDTN	RMT-10CDTN	RMT-15CDTN	RMT-20CDTN	RMT-30CDTN
Lifting Height (m)		6	12	8	12	8	12	8	12
Hoist Lifting Speed m/s (m/min)	50Hz	0.13 (7.5)	0.13 (7.5)	0.12 (7)	0.083 (5)	0.075 (4.5)	0.075 (4.5)	0.075 (4.5)	0.037 (2.2)
	60Hz	0.15 (9)	0.15 (9)	0.14 (8.4)	0.10 (6)	0.092 (5.5)	0.092 (5.5)	0.092 (5.5)	0.045 (2.7)
Hoist Motor		5.3	5.5	9	11	11	18.5	22	18.5
Hoist Lifting Speed m/s (m/min)	50Hz	0.013 (0.75)	0.013 (0.75)	0.012 (0.7)	0.0083 (0.5)	0.0075 (0.45)	0.0075 (0.45)	0.0075 (0.45)	0.0037 (0.22)
	60Hz	0.015 (0.9)	0.015 (0.9)	0.014 (0.84)	0.010 (0.6)	0.0092 (0.55)	0.0092 (0.55)	0.0092 (0.55)	0.0045 (0.27)
Hoist Motor		0.75	0.75	1.5	1.1	1.8	2.6	2.6	2.6
Trolley Speed m/s (m/min)	50Hz	0.35 (21)	0.35 (21)	0.35 (21)	0.35 (21)	0.31 (18.5)	0.31 (18.5)	0.31 (18.5)	0.31 (18.5)
	60Hz	0.42 (25)	0.42 (25)	0.42 (25)	0.42 (25)	0.37 (22)	0.37 (22)	0.37 (22)	0.37 (22)
Hoist Motor		0.4	0.4	0.75	0.75	0.75	1.5	1.5	2×1.5
Wire Rope	Falls	4	4	4	4	4	4	4	8
	Construction	6×Fi (29)							
Approx. Dimensions (mm)	L	6000	12000	6000	12000	8000	12000	8000	12000
	H	450	450	450	450	540	540	660	660
A	560	705	560	705	710	810	810	910	
B	615	760	615	760	830	930	980	1080	
C	555	700	555	700	715	815			
E	780	780	780	780	930	930	950	1230	
K1	460	460	460	460	470	470	630	630	
K2	420	420	420	420	505	505	520	520	
W	600	600	600	600	750	750	950	1000	
J1	200	200	200	200	250	250	260	260	
J2					25	25	15	15	
T	450	450	450	450	535	535	540	665	
R	650	900	650	900	900	1150	1300	900	
Y	400	700	400	700	560	760	750	600	
M	45	45	45	45	45	45	45	45	
G	15	15	15	15	20	20	20	20	
N1	φ150	φ150	φ150	φ150	φ150	φ150	φ150	φ200	
N2	φ178	φ178	φ178	φ178	φ178	φ178	φ178	φ230	
Approx. weight (kg)		500	550	500	550	900	960	1000	1050

Ordinary type

• Suspended

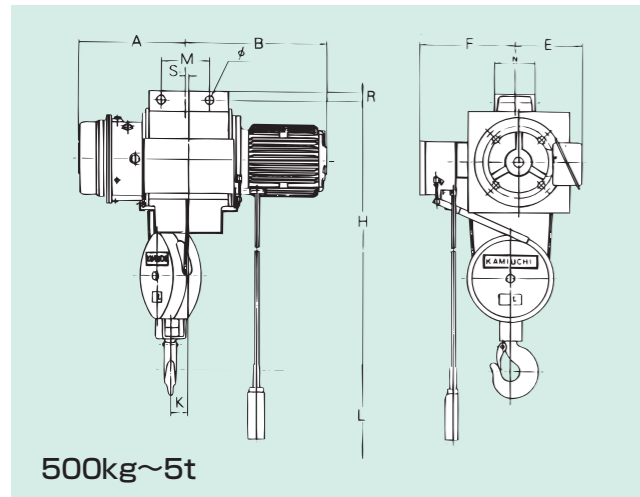

500kg~5t

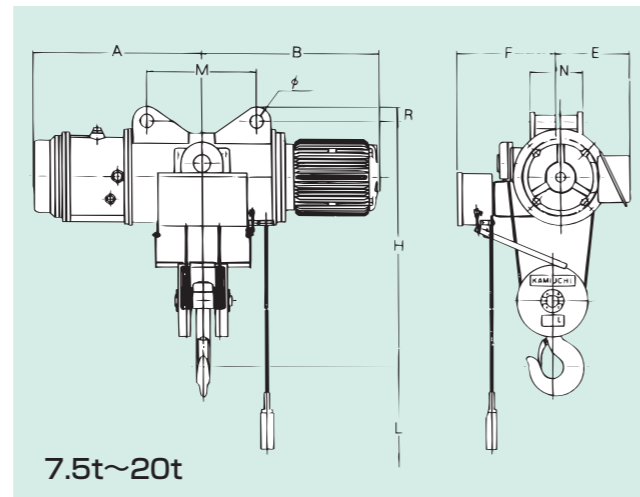

7.5t~20t

Specification

Rated Load		500kg		1t		2t		2.8t		3t		5t		7.5t		10t		15t		20t		
Model		RH-1/2CN	RH-1/2CHN	RH-1CN	RH-1CHN	RH-2CN	RH-2CHN	RH-2.8CN	RH-2.8CHN	RH-3CN	RH-3CHN	RH-5CN	RH-5CHN	RH-7.5CN	RH-7.5CHN	RH-10CN	RH-10CHN	RH-15CN	RH-15CHN	RH-20CN	RH-20CHN	
Lifting Height (m)		6	12	6	12	6	12	6	12	6	12	6	12	6	12	6	12	6	12	6	12	
Hoist	Hoist Lifting Speed m/s (m/min)	50Hz	0.17 (10)	0.17 (10)	0.13 (7.5)	0.13 (7.5)	0.13 (7.5)	0.12 (7)	0.083 (5)	0.075 (4.5)	0.075 (4.5)	0.075 (4.5)	0.075 (4.5)	0.075 (4.5)	0.075 (4.5)	0.075 (4.5)	0.075 (4.5)	0.075 (4.5)	0.075 (4.5)	0.075 (4.5)	0.075 (4.5)	
		60Hz	0.20 (12)	0.20 (12)	0.15 (9)	0.15 (9)	0.15 (9)	0.14 (8.4)	0.10 (6)	0.092 (5.5)	0.092 (5.5)	0.092 (5.5)	0.092 (5.5)	0.092 (5.5)	0.092 (5.5)	0.092 (5.5)	0.092 (5.5)	0.092 (5.5)	0.092 (5.5)	0.092 (5.5)	0.092 (5.5)	
	Hoist Motor	kW	1.5	2.6	3.7	5.3	5.5	9	11	11	18.5	22										
		Pole	4	4	4	4	4	4	4	6	6	4	4									
Rated Current (A)	200V 50Hz	7.0	11.5	16	24	24	34	48	48	68	86											
	200V 60Hz	6.6	11.5	16	24	24	34	48	48	68	86											
	220V 60Hz	6.6	10.5	15	23	23	32	46	46	64	82											
Wire Rope	Falls	2	2	2	2	2	2	4	4	4	4											
	Construction	6xW (19)		6xFi (29)																		
Approx. Dimensions (mm)	Dia (mm)	5	8	10	12.5	12.5	16	14	16	20	22.4											
	L	6000	12000	6000	12000	6000	12000	6000	12000	6000	12000	6000	12000	6000	12000	6000	12000	6000	12000	6000	12000	
	H	600	700	870	1020	1020	1250	1140	1350	1550	1600											
	A	335	405	370	445	430	500	470	560	470	560	660	710	910	780	955	935	1135	1010	1235		
	B	325	395	415	540	420	530	465	555	465	555	600	700	800	1000	785	960	875	1075	975	1200	
	E	175	205	255	255	255	290	285	330	365	365											
	F	290	330	365	415	415	475	550	690	750	770											
	K1	40	75	50	125	50	100	55	105	55	105	65	120									
	K2	40	70	50	75	45	75	50	90	50	90	50	100									
	M	150	150	220	220	220	240	500	450	600	750	1200										
	φ	22	22	32	32	32	39	45	45	60	75											
	N	125	125	150	150	150	200	240	240	240	240											
	R	25	25	30	30	30	40	45	45	65	75											
S	0	0	0	25	0	20	0	0	0	0												
Approx. weight (kg)		110	130	130	150	270	320	330	380	330	380	570	610	600	700	1150	1300	1700	1850	1850	2000	

KAMIUCHI HOIST SERIES APPLICABLE FOR ALL APPLICATION

Kamiuchi prepare so many and abundant hoist series that each customer can select according to their application. Please make the best use of Kamiuchi hoists, being proud of the outstanding actual sales and reliability, for rationalization and energy saving of transportation works and improvement of operation efficiency.

S-TYPE HOIST series (1t~3t)



Hoist of handy type and highly economical type.

Ordinary type

Low headroom type

Double rail type

Inverter type

K-TYPE HOIST series (500kg~60t)



Hoist of high reliability and complying with various needs. (Mechanical load brake, safety brake, is built in the gear case.)

Ordinary type

Low headroom type

Double rail type

Creep speed type

High lifting head type

All chain driving type

Home Hoist

- Handy tool at home, shop or factory.
- Small and light Home Hoist is portable, yet it lifts max. 200kg.



Model	KL-1E	KLC-1E
Rated Load	200kg	
Hoist Lifting Speed	0.050 - 0.083m/s (3 - 5m/min)	0 - 0.083m/s (0 - 5m/min)
Control Voltage	50/60Hz 100V	
Hoist Motor	140W	
Net Weight	Approx. 7kg	
Lifting Height	3m · 6m	
Chain	Link chain (φ5)	
Control	Pushbutton pendant	Sheet switch fixed speed

Air Hoist

- Installable anywhere if air feed piping is available.
- Weighing only 15.5kg.



Model	AH-1RN	AH-2RN
Rated Load	500kg	1000kg
Air Pressure	58.8Pa (6kg/cm ²)	
Lifting Height	3m	
Hose Aperture	12.7mm	
Hoist Lifting Speed (Rated load)	0.23m/s (14m/min)	0.12m/s (7m/min)
Air Consumption	1.3m ³ /min	
Net Weight	15.5kg	21.5kg